

MAKE CLEAN LINE  
 SAVING AREA AS MUCH AS  
 POSSIBLE AND ALL DIMENSIONS

SHIT. 7 - [unclear]

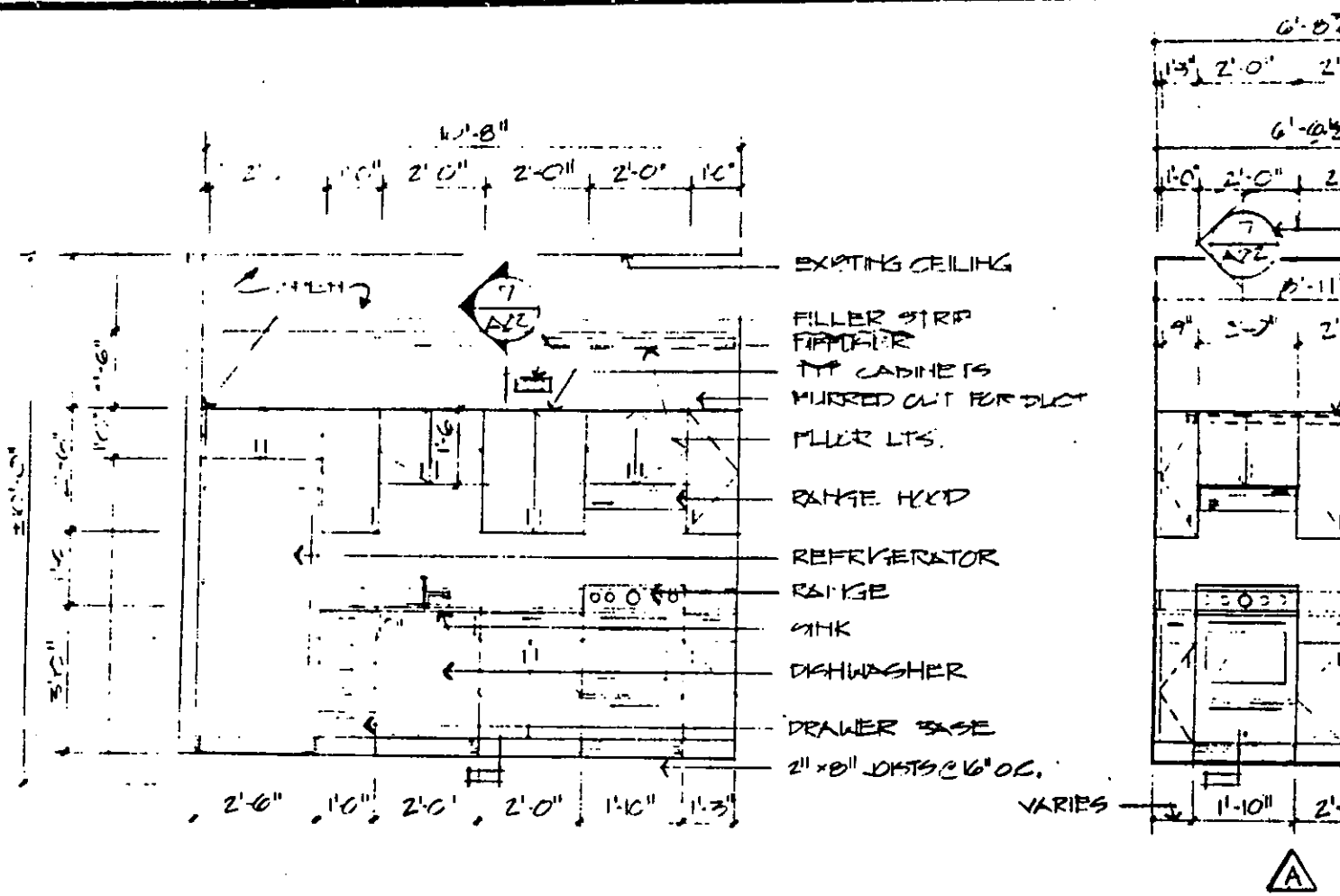

① KITCHEN ELEVATION  
 2'10" = 1'-0"

② KITCHEN  
 7'10" = 1'-0"

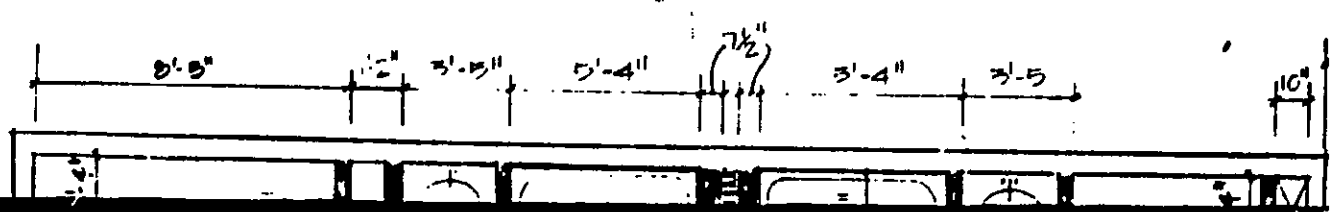

BKH 142 PG 895

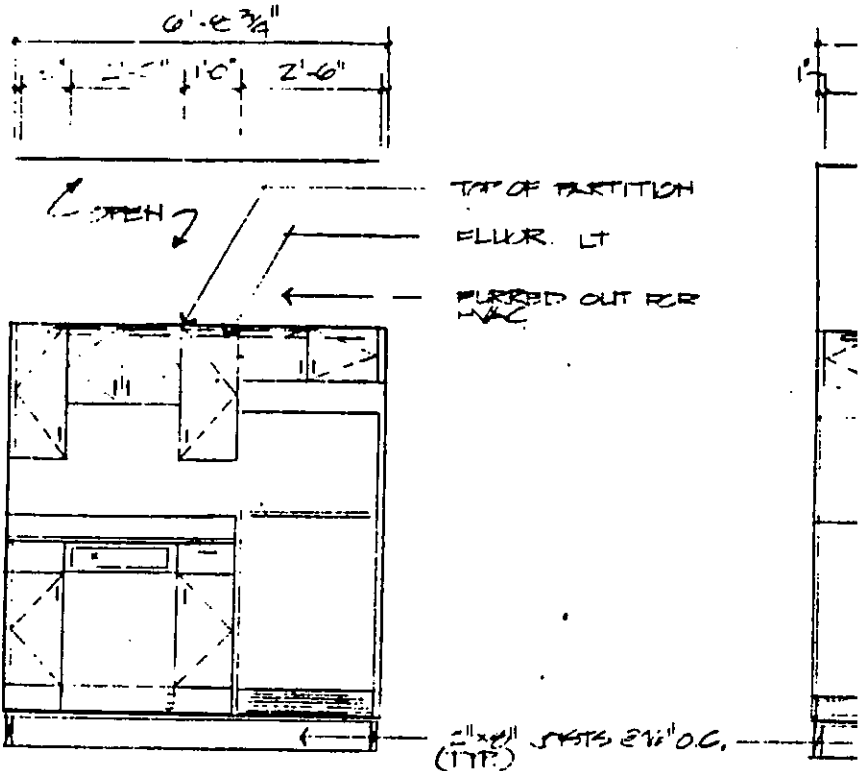
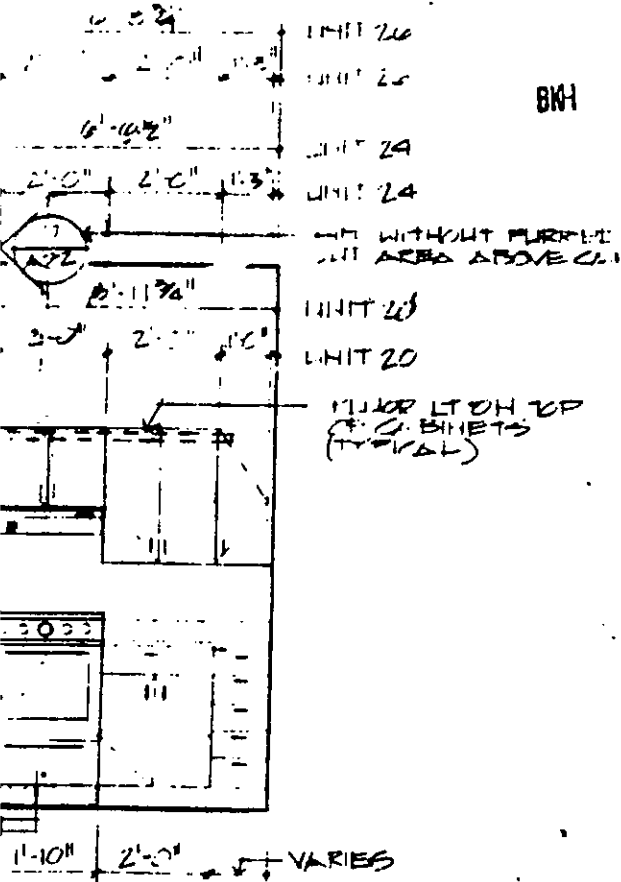

A

B

KITCHEN ELEVATIONS SEE FOR NOTES AND DIM'S NOT SHOWN

K17 2/10

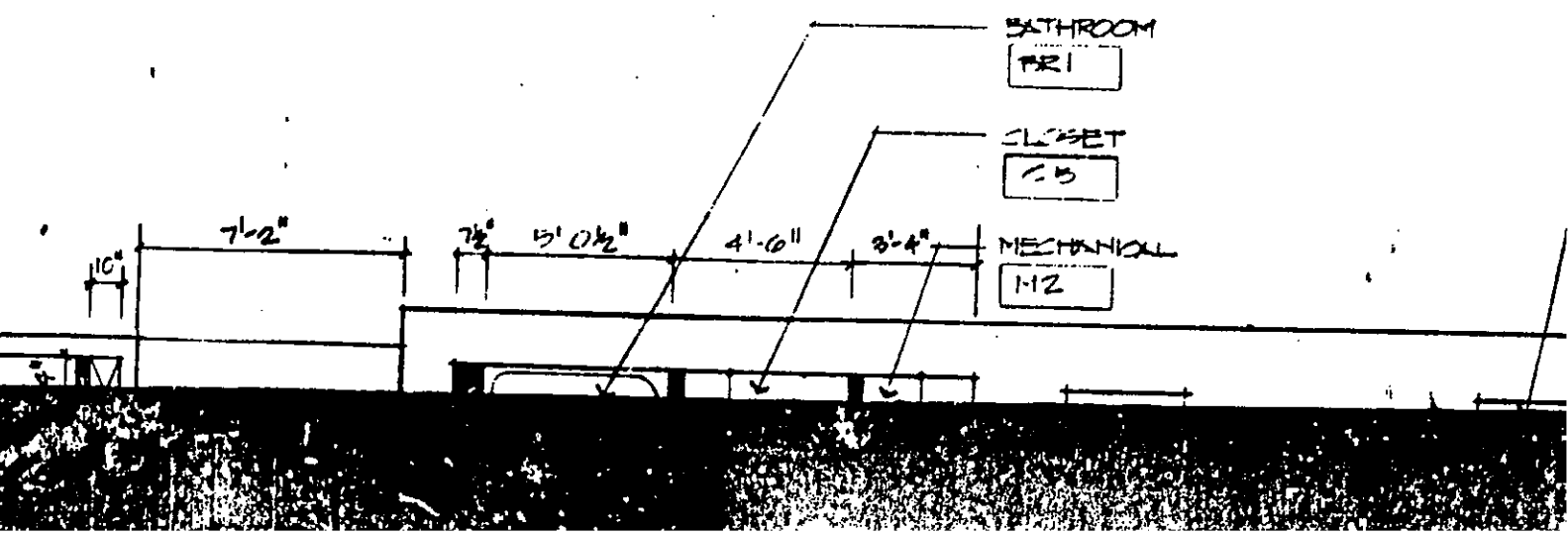

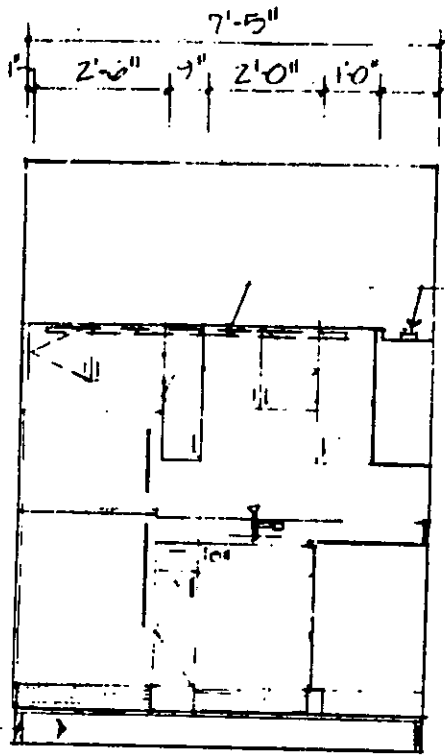

△ A

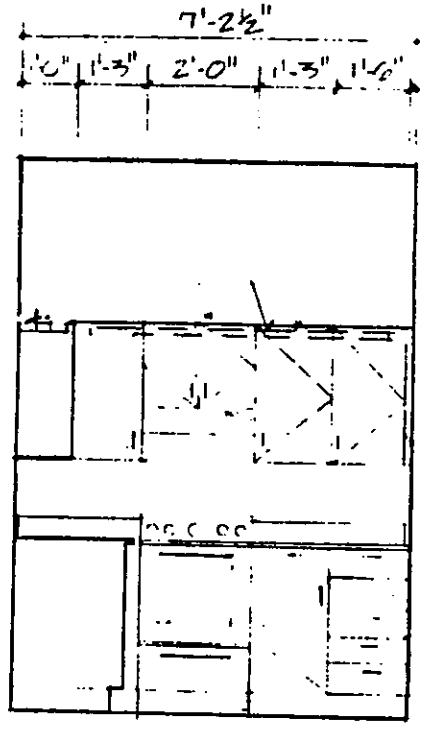

△ B

③ KITCHEN ELEVATIONS SEE ① FOR NOTES AND DIMS NOT SHOWN  
 5/10' = 1'-0"

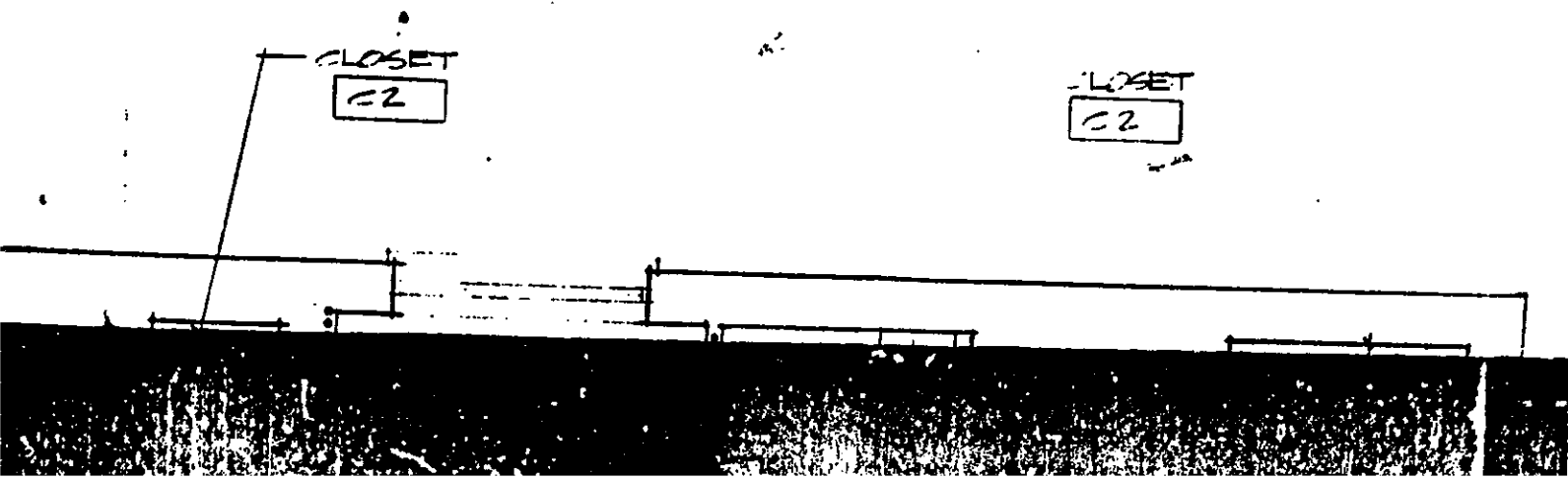

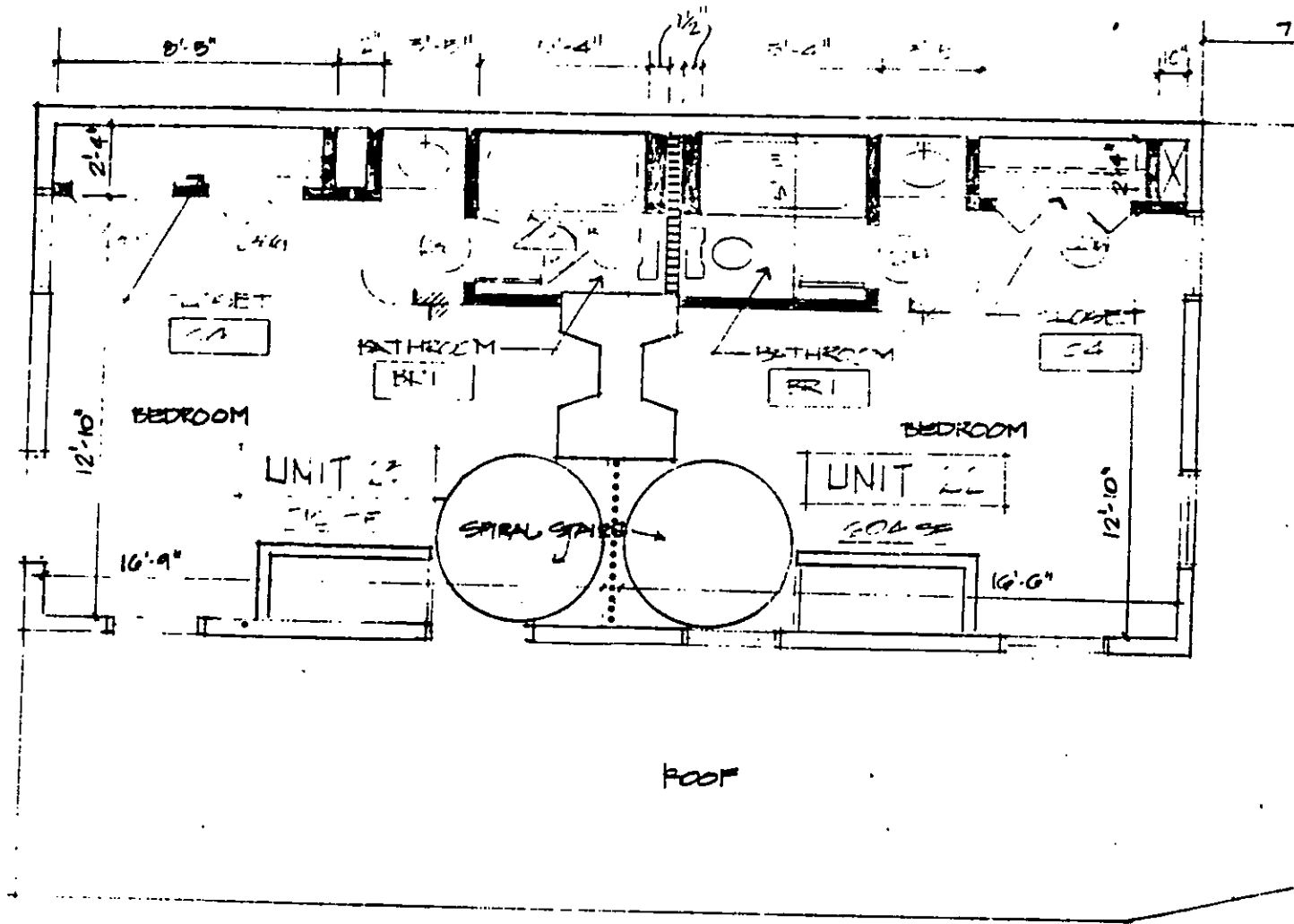

4 PLAN OF 2ND FLOOR - HOUSE 313 MEETING STREET  
 1/4" = 1'-0"





LOSET  
C2

LOSET  
C2

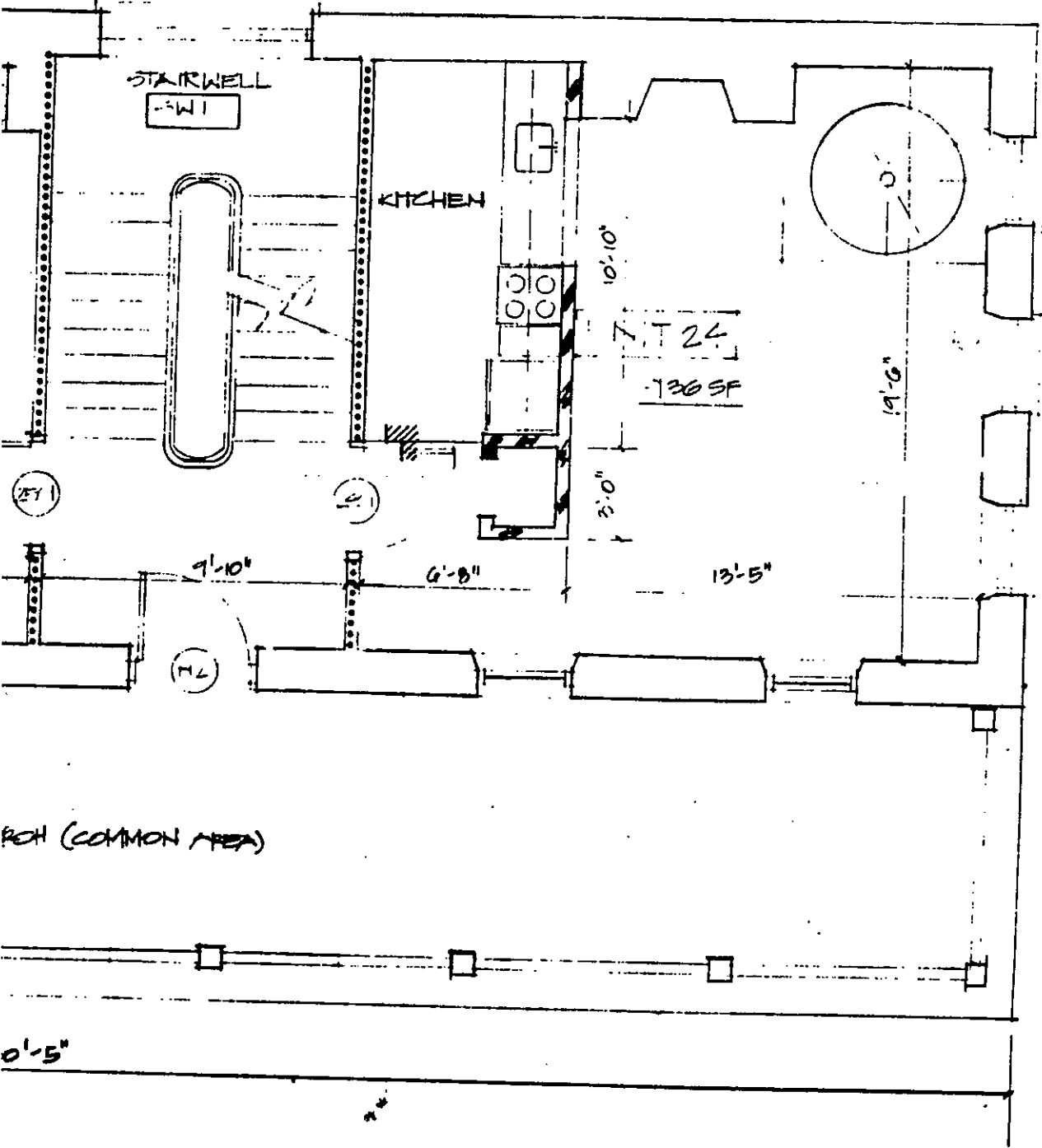

SHT. 8 12/26/84



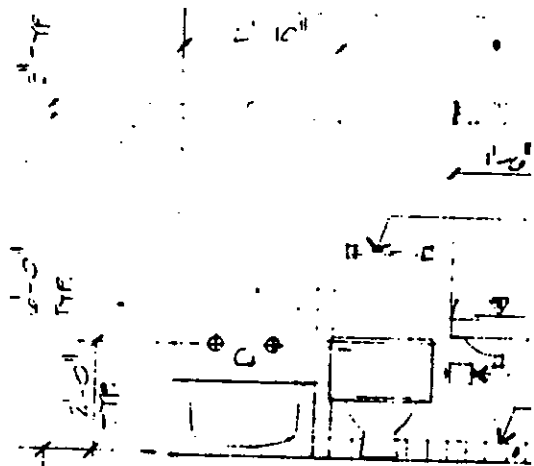
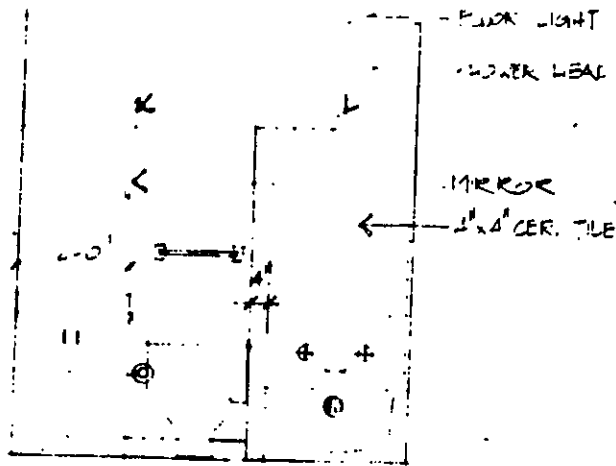

① BATHROOM ELEVATION  
1/8" = 1'-0"

② BATHROOM EI  
1/8" = 1'-0"

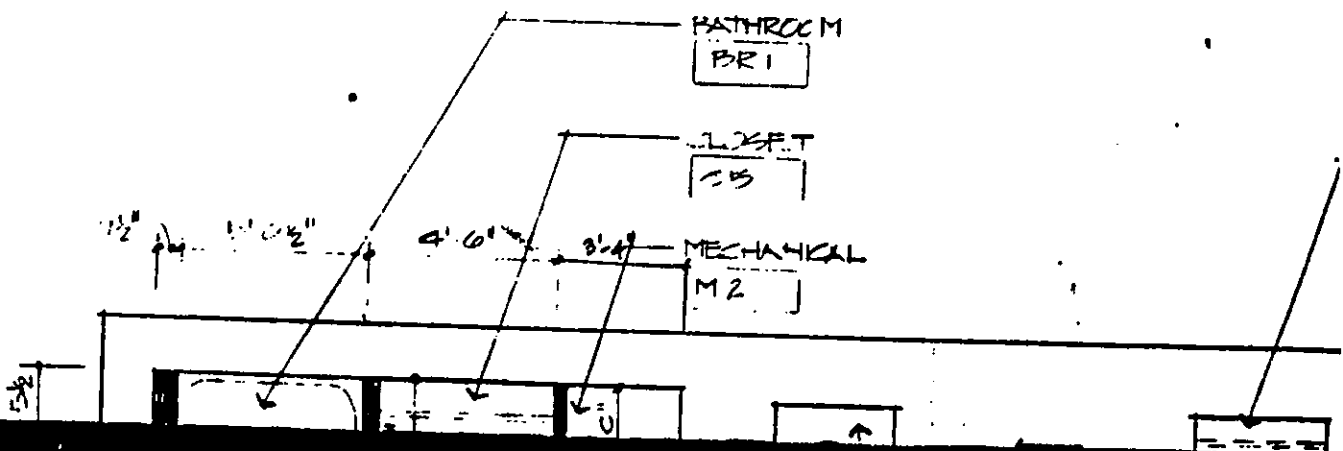

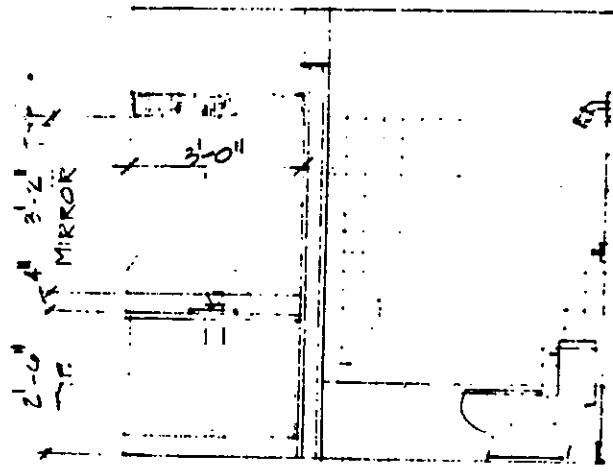
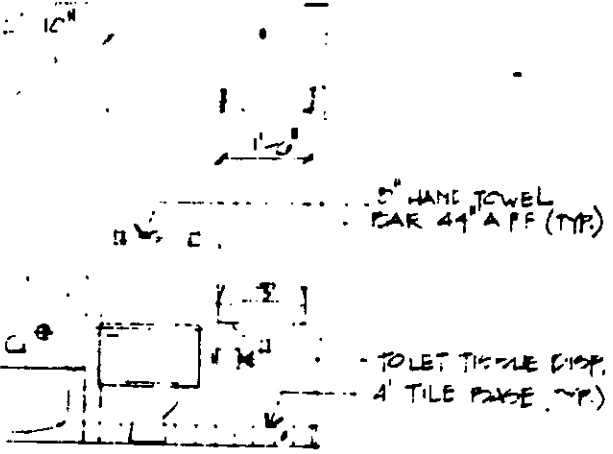

A

TRF.COM ELEVATION  
= 1'-0"

3 BATHROOM ELEVATIONS  
= 1'-0"

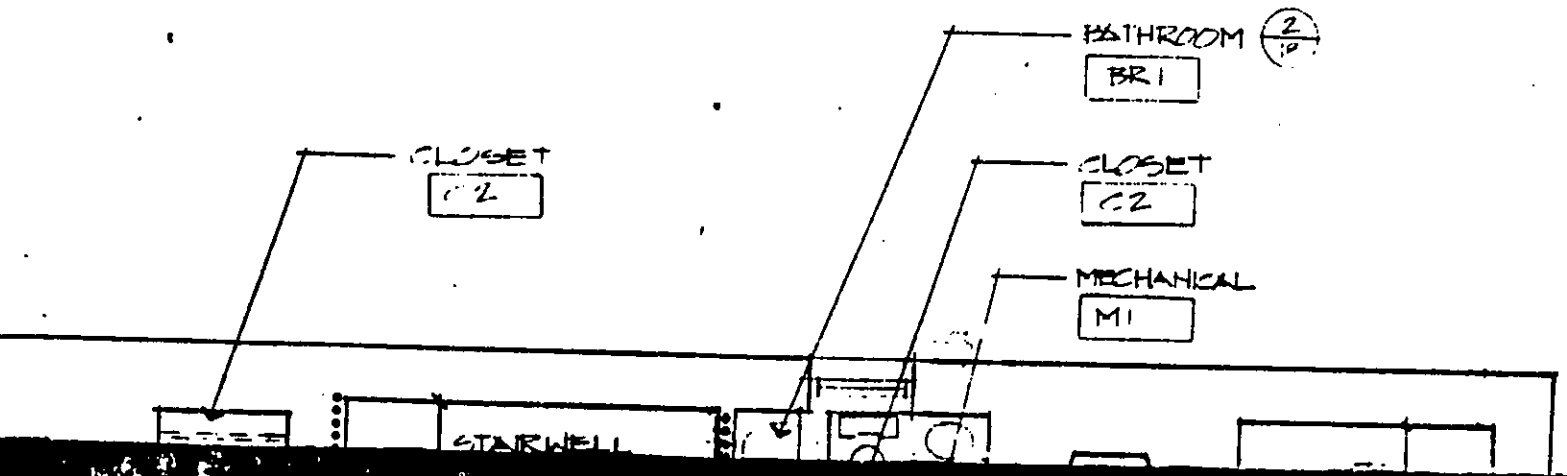

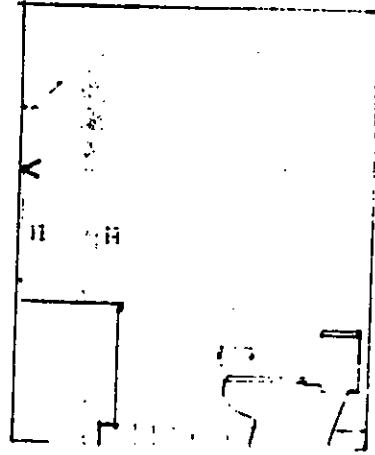

20" W MIRROR

4 BATHROOM ELEVATION  
 1/8" = 1'-0"

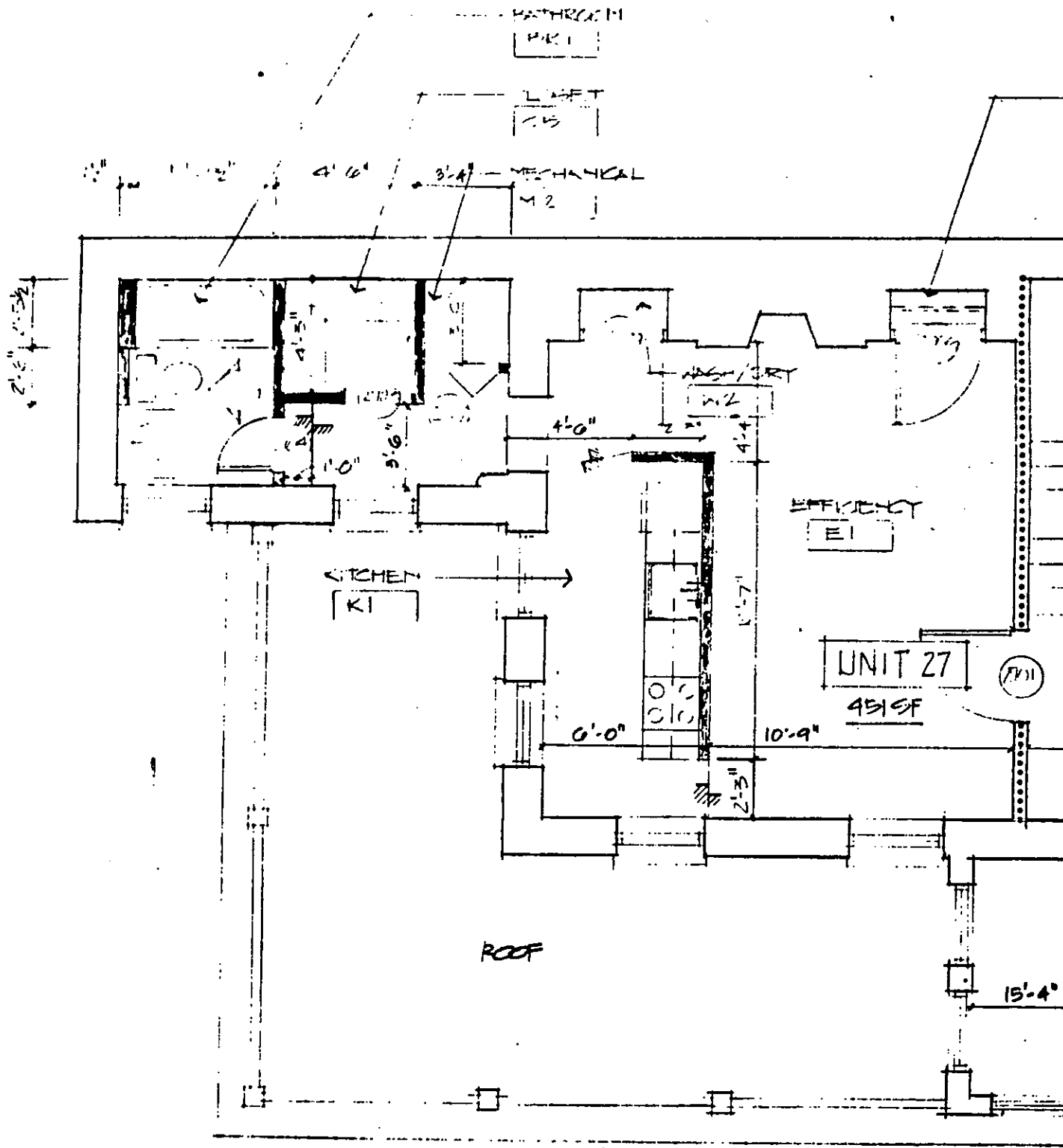

PLAN - 3RD FLOOR - HOUSE 313 MEETING STR  
 14' = 1'-0"



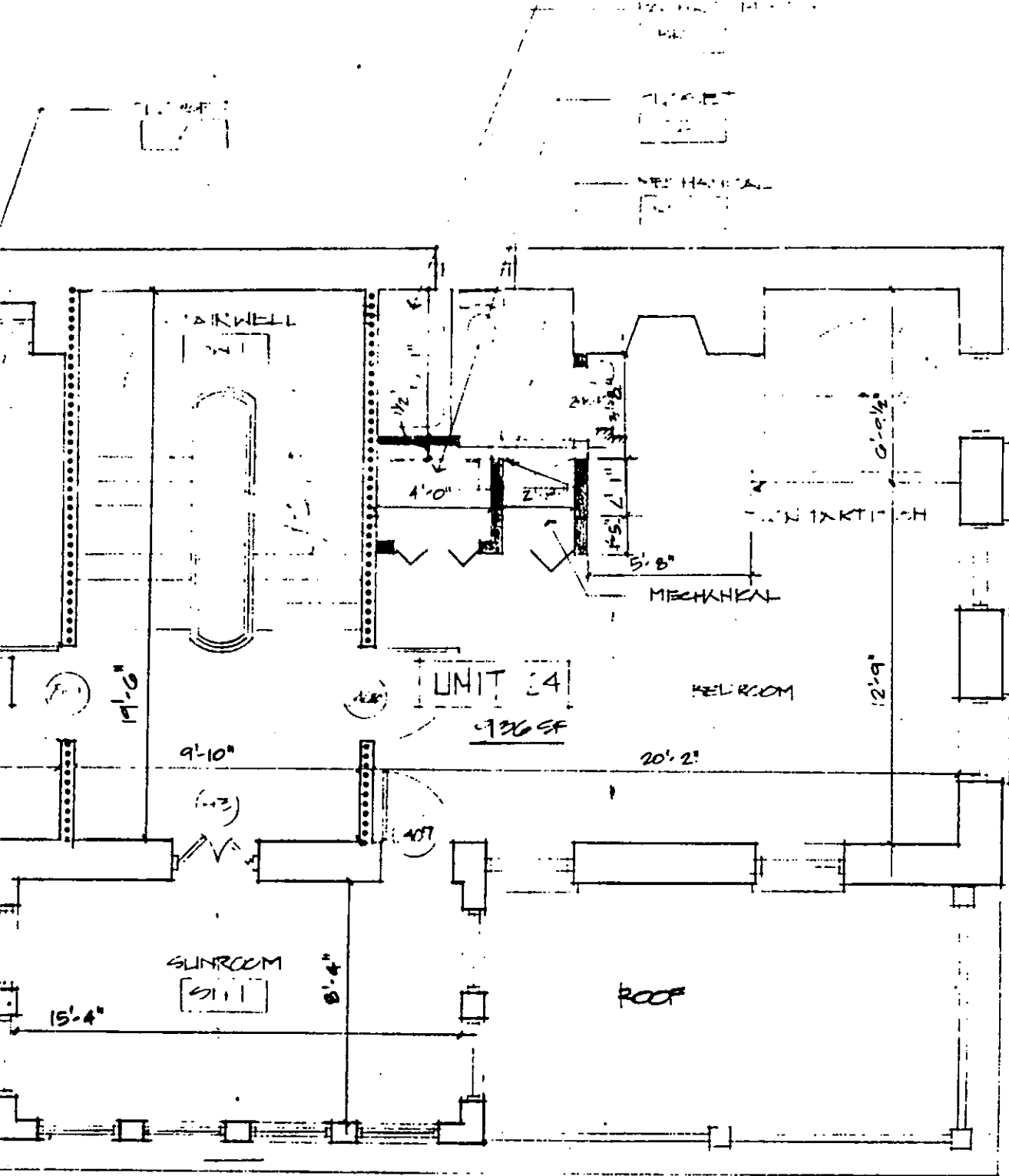

STREET

Document Continues  
Use Manual Search!

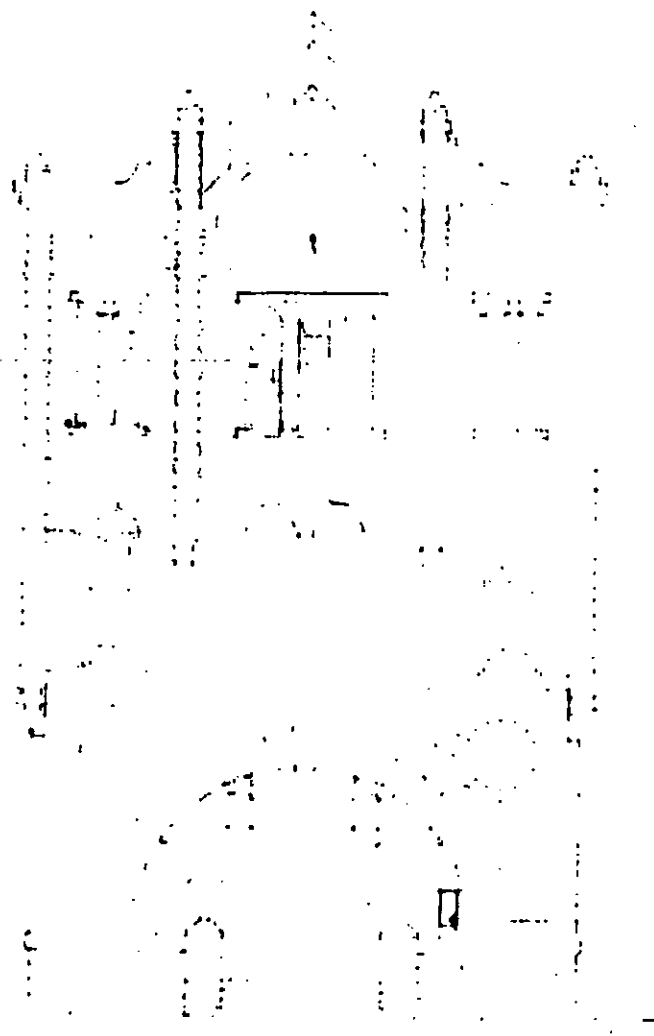

MEETING ST. ELEVATION 309 MEETING ST.

SCALE 1/2" = 1'-0"

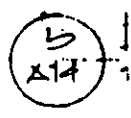
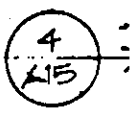

SCALE

1/2" = 1'-0"

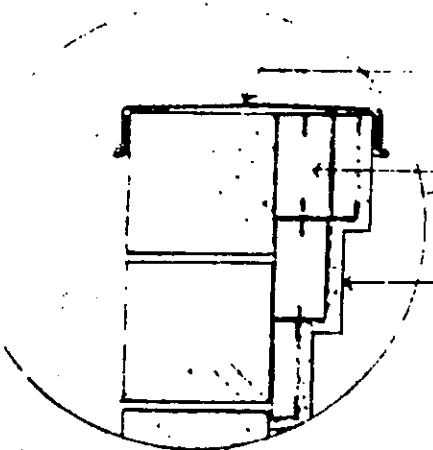

METAL COPING CENTER  
 1/2" METAL STUDS  
 PLASTER OVER METAL LATH

4 DETAIL AT STARTOWER

1/2" = 1'-0"

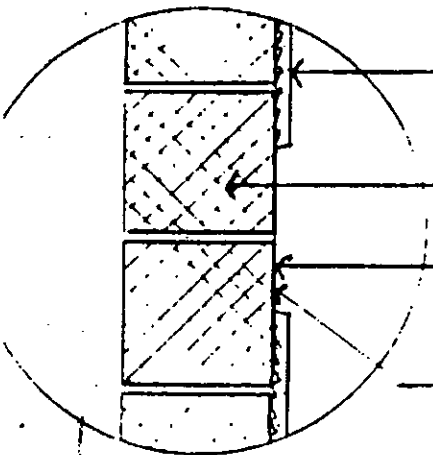

PLASTER OVER METAL LATH  
 8" CMU  
 PAINTED REVEAL TO MATCH SIZE AND LOCATION OF ON EXISTING MASONRY  
 PLASTER OVER METAL LATH

SCALE 1/2" = 1'-0"

5 DETAIL AT STARTOWER

1/2" = 1'-0"

SEE DRAWING FOR  
 LAYOUT (SEE ELEC DWG)

STREET

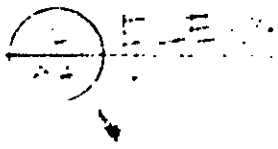
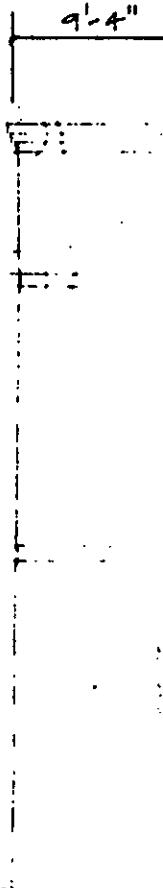

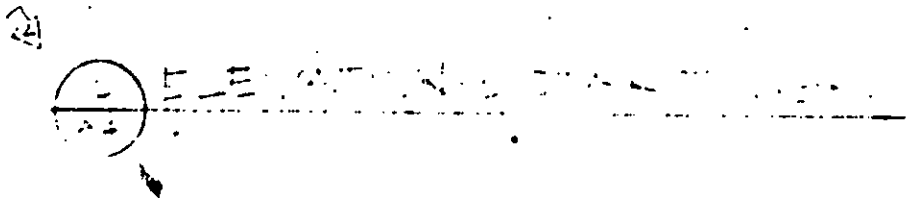
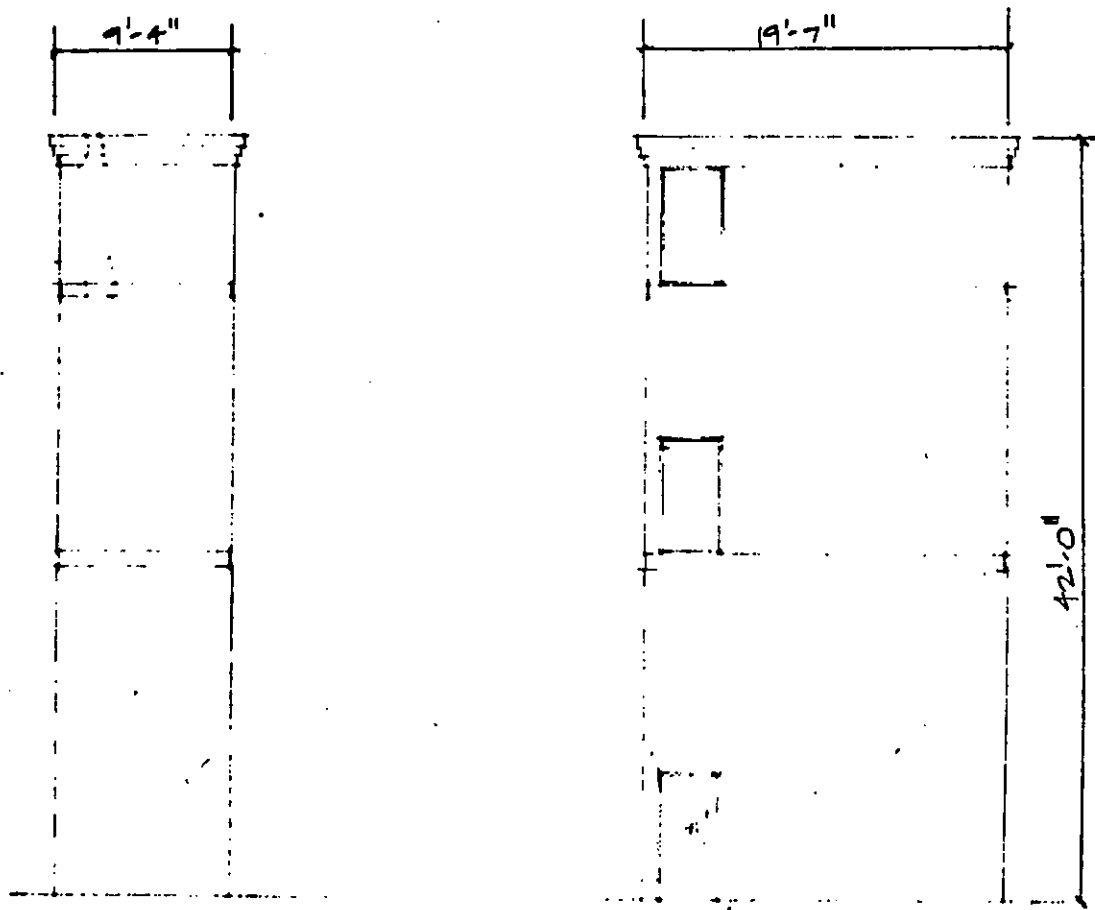



(2) FRONT ELEVATION 309 MEETING STREET

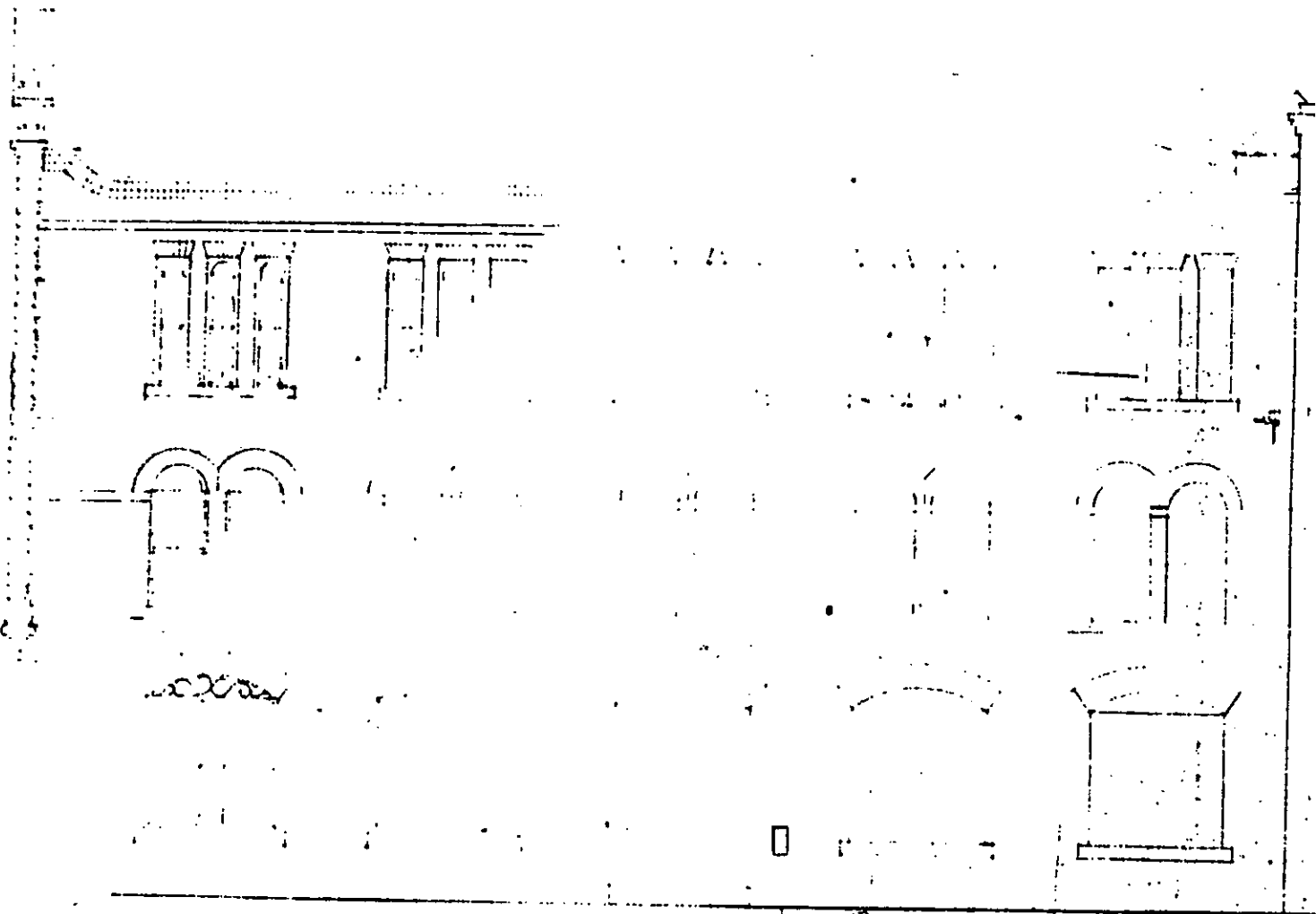

STATION IDENTIFYING DEVICE (SEE ELEC DWGS) ←

(2) COURTYARD ELEVATION 309 MEETING STREET

SCALE: 1/8" = 1'-0"  
SEE SHEET AND PLAN FOR DETAILS

STREET

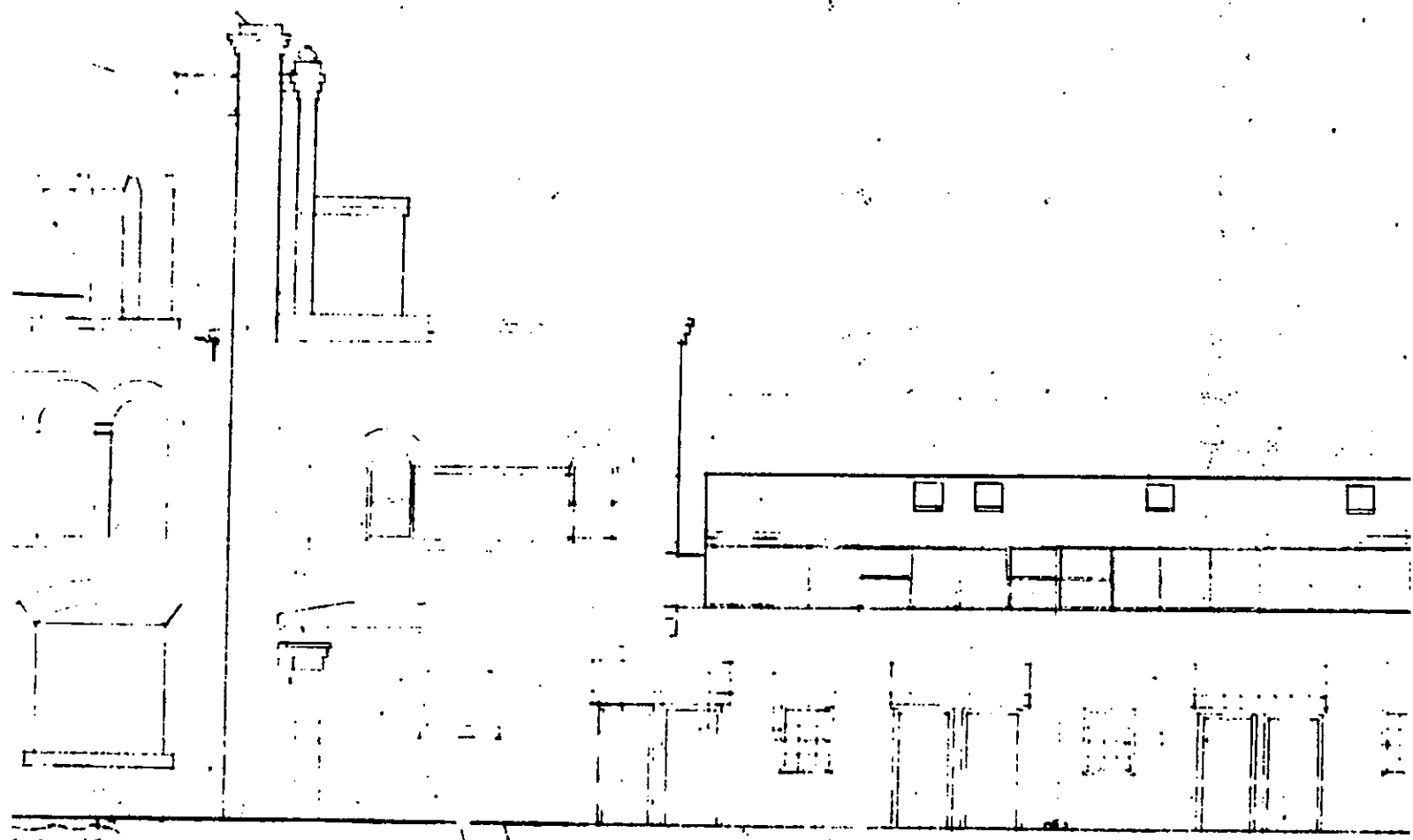
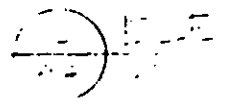

BY NG  
C. D. K. S. J.

STREET

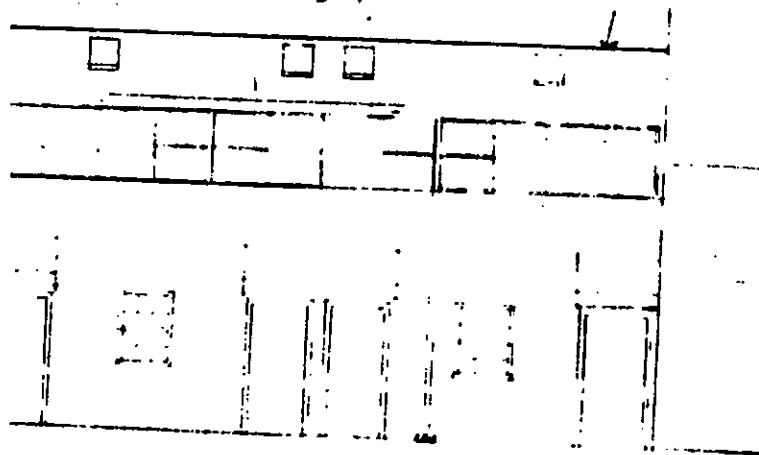

2ND FLOOR VIEW OF AREA

1. FLOOR PLAN  
 2. ELEVATION (WEST)  
 3. ELEVATION (EAST)  
 4. SECTION THROUGH  
 5. SECTION THROUGH

SHT. 10 12/26/84

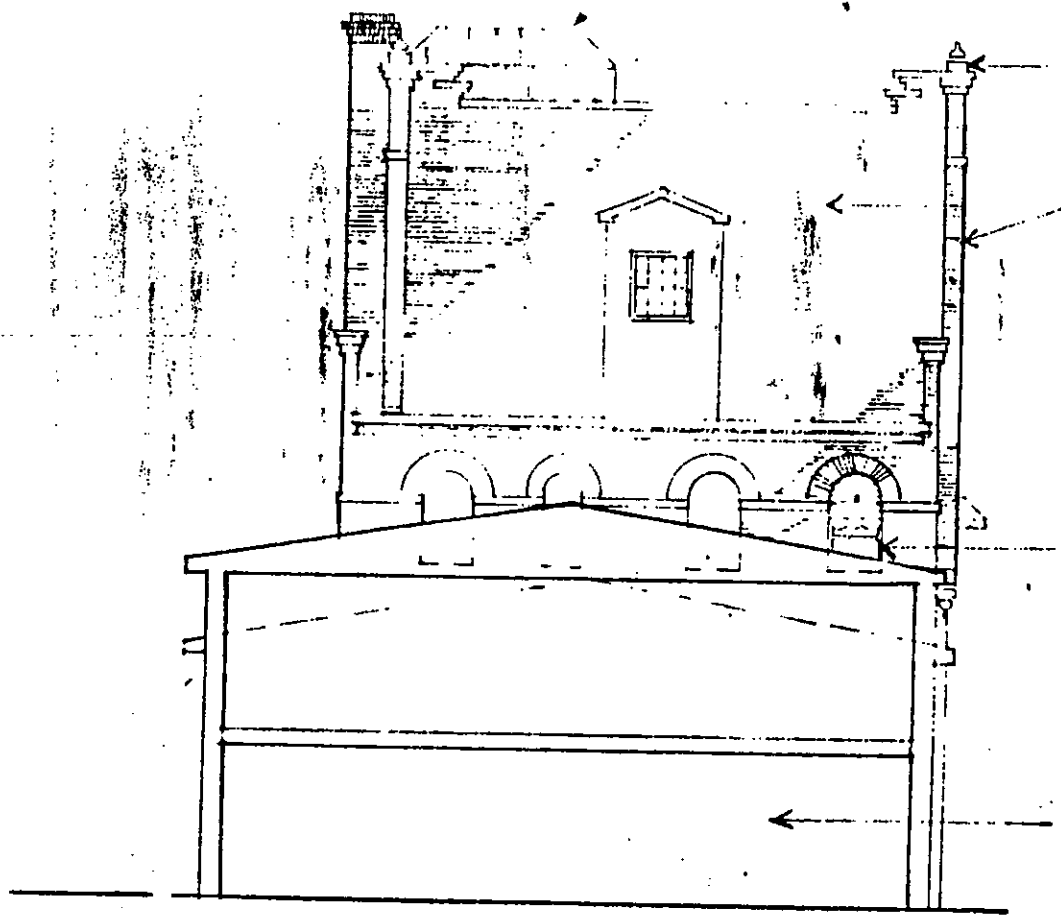

SECTION THRU GARAGE  
 $\frac{1}{8}'' = 1'-0''$

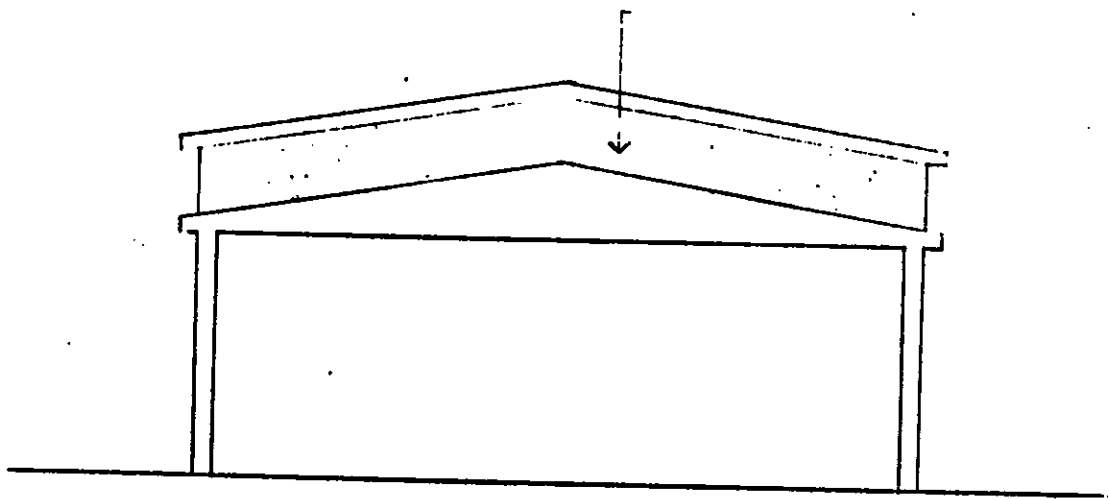

2  
15

SECTION THROUGH ROOF

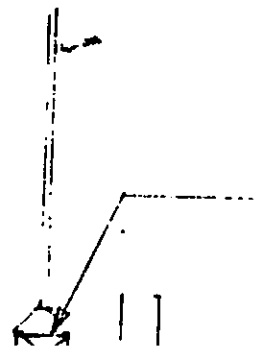

1/8" = 1'-0"

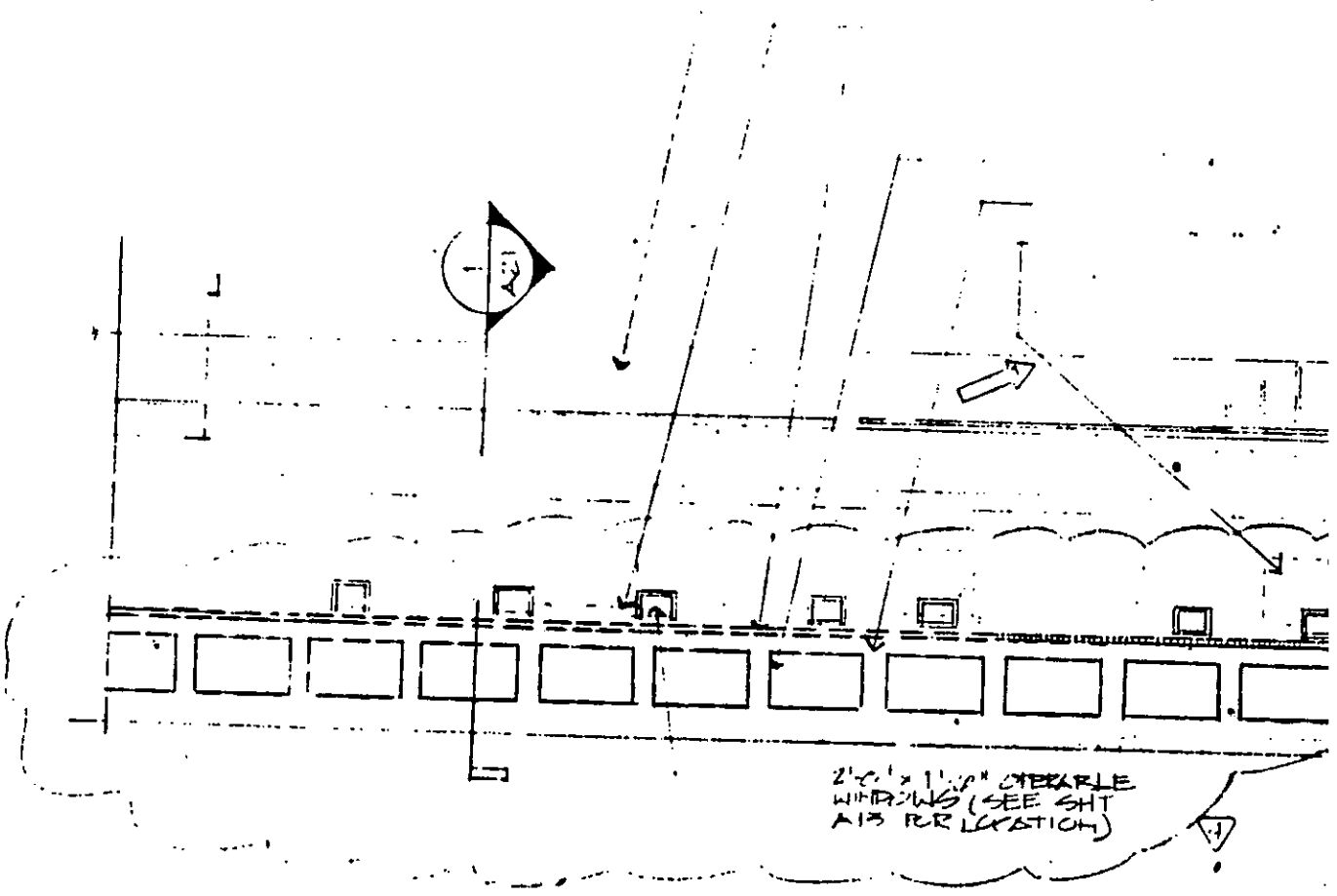

2  
15

WJENS LANE ELEVATION 309 MEETING S

1/8" = 1'-0"

BKH 142PG899



PROVIDE 4 MIL POLY IN CRAWL SPACE

PROVIDE LOUVERED SCREENS AT PORCH



(1) COURTYARD ELEVATION 313 MEETING STREET  
(2) 1/8" = 1' 0"

(3) PROVIDE  
AT PORCH



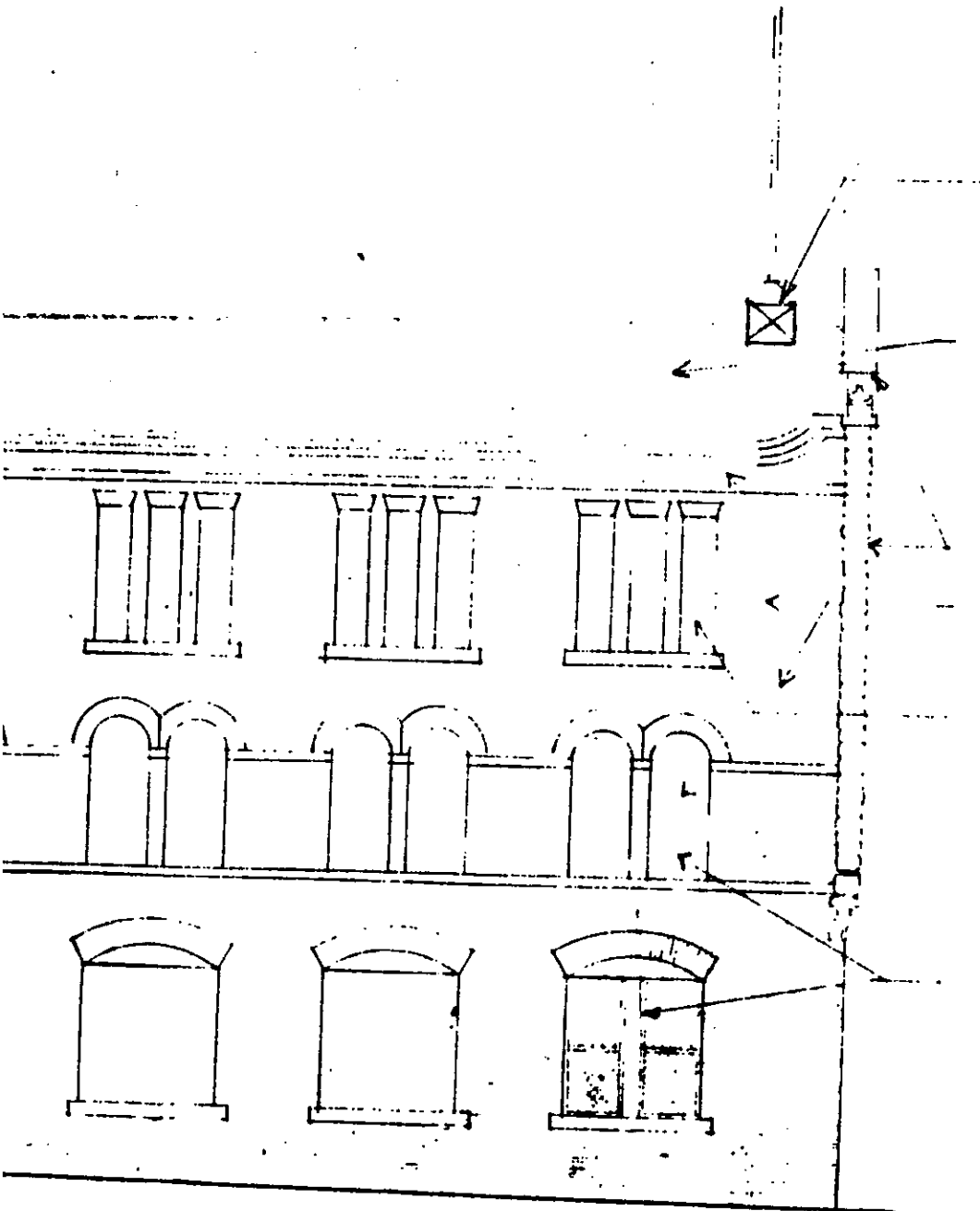

SHT. II K-126-130